

# CARTER

## CT36/37

### Ekonomik ve Verimli Kolay Bakım Dayanıklılık

- Standart Kabin
- Yanmar Euro V Motoru
- Açılır Kapanır Paletler
- Yüke Duyarlı Hidrolik Sistemler
- Sıfır Kuyruk
- Klima



Özellikler	Birim	CT36B	CT36B4	CT37B
Kendi ağırlığı	T	3.75	3.75	3.75
Kepçe kapasitesi	m <sup>2</sup>	0.12	0.12	0.12
Motor modeli		YANMAR 3TNV88F	YANMAR 3TNV88	YANMAR 3TNV88F
Anma gücü	kw/r/min	18.2/2200	20.2/2200	18.2/2200
Maks. akış	L/min	88	88	88
Çalışma basıncı	Mpa	24.5	24.5	24.5
Yakıt deposu kapasitesi	L	50	50	50
Hidrolik yağ tankı kapasitesi	L	40	40	40
Seyahat hızı	km/h	2.2/4.2	2.2/4.2	2.2/4.2
Dönüş hızı	r/min	9.5	9.5	9.5
Maks. tırmanma derecesi	%	58	58	58
Kol kazma kuvveti	KN	18.2	18.2	18.2
Kepçe kazma kuvveti	KN	30.4	30.4	30.4
Ortalama topraklama basıncı	Kpa	32.0	32.0	32.0

Çalışma Aralığı	Birim	CT36B	CT36B4	CT37B
O-Maks. kazma yüksekliği	mm	4855	4855	4855
P-Maks. boşaltma yüksekliği	mm	3460.0	3460.0	3460.0
O-Maks. kazma derinliği	mm	3105	3105	3105
R-Maks. dikey duvar kazma derinliği	mm	2700.0	2700.0	2700.0
T-Maks. kazma erişimi	mm	5465	5465	5465
U-Maks. zemin seviyesinde kazma erişimi	mm	5350.0	5350.0	5350.0

Genel Boyut	Birim	CT36B	CT36B4	CT37B
A-Toplam uzunluk	mm	4920.0	4920.0	4920.0
B-Toplam genişlik	mm	1720	1720	1720
C-Toplam yükseklik (bomun tepesine)	mm	1800.0	1800.0	1800.0
D-Toplam yükseklik (taksinin tepesine)	mm	2550/2520	2550/2520	2550/2520
E-Karşı ağırlık yerden yükseklik	mm	580.0	580.0	580.0
F-Min. yerden yükseklik	mm	295	295	295
G-Kuyruk dönüş yarıçapı	mm	860.0	860.0	860.0
H-Palet zemin uzunluğu	mm	1710	1710	1710
J-Palet uzunluğu	mm	2160.0	2160.0	2160.0
K-Palet göstergesi	mm	1420	1420	1420
L-Palet genişliği	mm	1710.0	1710.0	1710.0
M-Palet pabucu genişliği	mm	300	300	300

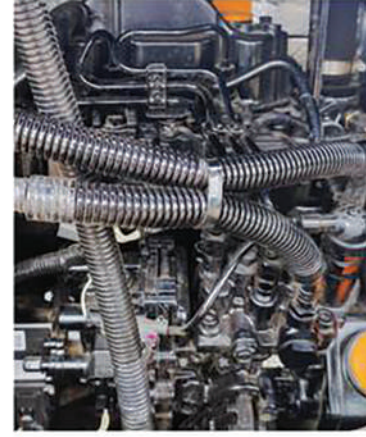
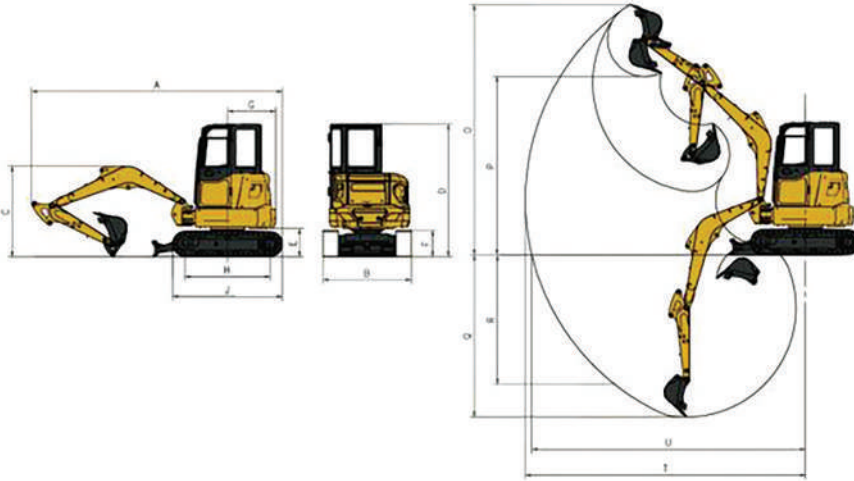

Mini  
Ekskavatör

Küçük  
Ekskavatör

Orta  
Ekskavatör

Büyük  
Ekskavatör



[www.edmakine.com](http://www.edmakine.com)

[carterturkiye@gmail.com](mailto:carterturkiye@gmail.com)



Türkiye Resmi Distribütörü  
Ed Makine



web sitesi



instagram